

# 1200 Series 1206D-E70TTAG1 Diesel Engine – ElectropaK

204.2 kWm (Gross) @ 1500 rpm

240 kWm (Gross) @ 1800 rpm

Perkins is pleased to announce the natural expansion of the 1200 Series to include a new addition to the ElectropaK range.

The whole engine has been built around the demands of our customers and as such offers a great package with a simple integration design.

Perkins have developed a reputation for designing and building reliable and durable engines suitable for the most demanding applications.

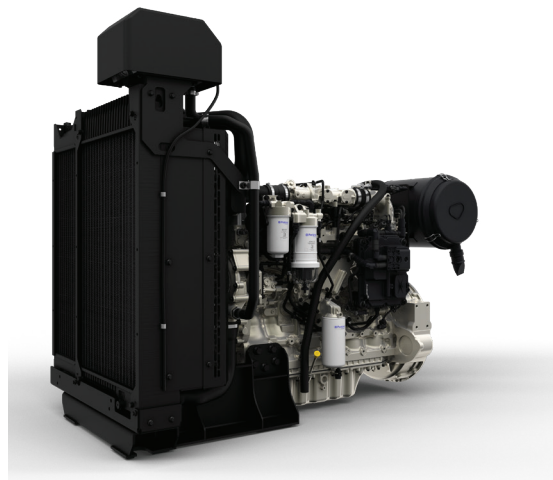

## Emissions

EU Stage IIIA.

Specification		
Number of cylinders	6 vertical in-line	
Bore and stroke	105 x 135 mm	4.13 x 5.3 in
Displacement	7.01 litres	427.7 in <sup>3</sup>
Aspiration	Series turbocharged aftercooled	
Cycle	4 stroke DI	
Combustion system	Direct injection	
Compression ratio	15.8:1	
Rotation	Anti-clockwise, viewed on flywheel	
Total lubricating capacity	13-16 litres	3.4-4.2 US gal
Cooling system	Liquid	
Total coolant capacity	25 litres	6.6 US gal

[www.perkins.com](http://www.perkins.com)

Photographs are for illustrative purposes only and may not reflect final specification. All information in this document is substantially correct at time of printing and may be altered subsequently. Final weight and dimensions will depend on completed specification.

Publication No. PN3183/06/18 Produced in England ©2018 Perkins Engines Company Limited

 **Perkins**<sup>®</sup>

THE HEART OF EVERY GREAT MACHINE

# 1200 Series 1206D-E70TTAG1 Diesel Engine – ElectropaK

204.2 kWm (Gross) @ 1500 rpm

240 kWm (Gross) @ 1800 rpm

## Features and benefits

### Dependable power

- World-class manufacturing capability and processes coupled with proven core engine designs assure reliability, quiet operation, and many hours of productive life
- Series turbocharging with smart wastegate available on all ratings
- A high power density product that combine dependable power and high efficiency at the same time. Driving lower cost of ownership along with better performance

To find more, visit: [www.perkins.com/powerdensity](http://www.perkins.com/powerdensity)

### Flexibility

- Tropical radiator is supplied as standard

### Lifetime of low cost

- Fuel consumption optimized prime power and continuous running applications. No additional fluids or additives are required which lowers operating costs
- Hydraulic tappets, multi-vee belts and 500-hour oil change intervals enable low-cost maintenance
- Perkins Platinum Protection – there is also an option to buy a Perkins Platinum Protection policy to cover you beyond the standard warranty period.

Discover more: [https://www.perkins.com/en\\_GB/aftermarket/perkins-platinum-protection.html](https://www.perkins.com/en_GB/aftermarket/perkins-platinum-protection.html)

### Local support, global coverage

- Perkins recognise that the customer relationship is important to machine manufacturers and we can offer a range of flexible solutions to help provide appropriate support, either to the OEM's network or directly to the machine customer
- Perkins information systems enable our distributors to quickly diagnose engine faults and identify the right parts. The Perkins logistics operation is able to dispatch more than 45,000 different parts from stock, reaching the customer within 24 hours
- To find your local distributor: [www.perkins.com/distributor](http://www.perkins.com/distributor)

[www.perkins.com](http://www.perkins.com)

Photographs are for illustrative purposes only and may not reflect final specification.  
All information in this document is substantially correct at time of printing and may be altered subsequently.  
Final weight and dimensions will depend on completed specification.

Publication No. PN3183/06/18 Produced in England ©2018 Perkins Engines Company Limited

 **Perkins**<sup>®</sup>

THE HEART OF EVERY GREAT MACHINE

# 1200 Series 1206D-E70TTAG1 Diesel Engine – ElectropaK

204.2 kWm (Gross) @ 1500 rpm

240 kWm (Gross) @ 1800 rpm

## Technical information

### Air inlet

- Standard air cleaners

### Control system

- Full electronic control system
- All connectors and wiring looms waterproof and designed to withstand harsh environments
- Flexible and configurable software features and well supported SAE J1939 CAN bus enables highly integrated machines

### Cooling system

- Tropical radiator as standard ensures optimal cooling performances all year round in any state
- 50:50 water glycol mix

### Flywheels and flywheel housing

- SAE2 flywheel housing

### Fuel and fuel system

- Electronic high pressure common rail
- Innovative filter design – ensures maximum protection of the engine
- Flat bottomed, isolated, aluminium sump

## Dimensions

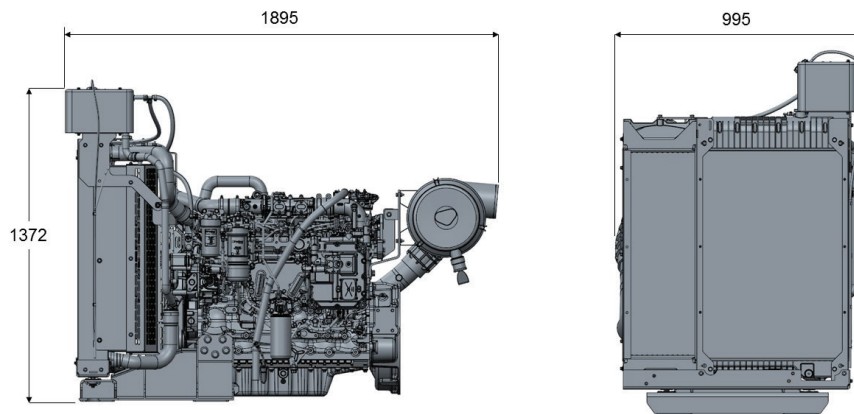

Engine package weights and dimensions		
Length (including air filter)	1895 mm	74.6 in
Width	995 mm	39.2 in
Height	1372 mm	54.0 in
Weight (dry)	807.7 kg	1780.7 lb

[www.perkins.com](http://www.perkins.com)

Photographs are for illustrative purposes only and may not reflect final specification. All information in this document is substantially correct at time of printing and may be altered subsequently. Final weight and dimensions will depend on completed specification.

Publication No. PN3183/06/18 Produced in England ©2018 Perkins Engines Company Limited

 **Perkins**<sup>®</sup>

THE HEART OF EVERY GREAT MACHINE

# 1200 Series 1206D-E70TTAG1 Diesel Engine – Electropak

204.2 kWm (Gross) @ 1500 rpm

240 kWm (Gross) @ 1800 rpm

Speed rpm	Type of operation	Generator output		Engine power			
				Gross		Net	
		kVA	kWe	kWm	hp	kWm	hp
1500	Prime power	200	160	185.8	249.1	176.8	236.9
	Standby power	225	180	204.2	273.7	195.2	261.7
1800	Prime power	225	180	216.6	290.5	201.6	270.4
	Standby power	250	200	238.6	319.9	223.6	299.8

Power rating %	185.8 kW/1500 rpm Prime		216.6 kW/1800 rpm Prime	
	g/kWh	litres/hr	g/kWh	litres/hr
25	237.2	13.1	257	16.5
50	212.4	23.5	216.4	27.8
75	208.9	34.7	209.3	40.4
100	206.9	45.8	211.7	54.5
110	209.7	51	215.2	61.1

[www.perkins.com](http://www.perkins.com)

Photographs are for illustrative purposes only and may not reflect final specification.  
All information in this document is substantially correct at time of printing and may be altered subsequently.  
Final weight and dimensions will depend on completed specification.

Publication No. PN3183/06/18 Produced in England ©2018 Perkins Engines Company Limited



THE HEART OF EVERY GREAT MACHINE